

COMMAND LIGHT

SHADOW SERIES



Effective September 2024
This guide supersedes all previous versions

3842 Redman Drive
Fort Collins, CO 80524

MODEL COVERED:
SL442D-80-24V

1-800-797-7974
www.CommandLight.com

THANK YOU

Please allow us to express a simple thank you for investing in a **COMMAND LIGHT** product. As a company, we are dedicated to producing the very best and most versatile flood lighting package available. We take great pride in the quality of our work and hope that you will find many years of satisfaction from the use of this equipment.

Should you have any problems with your product please do not hesitate to contact us.



3842 Redman Drive
Fort Collins, CO 80524

PHONE: 1-800-797-7974

FAX: 1-970-297-7099

WEB: www.CommandLight.com



DANGER

PERSONAL RESPONSIBILITY CODE

The member companies of FEMSA that provide emergency response equipment and services want responders to know and understand the following:

1. Firefighting and Emergency Response are inherently dangerous activities requiring proper training in their hazards and the use of extreme caution at all times.
2. It is your responsibility to read and understand any user's instructions, including purpose and limitations, provided with any piece of equipment you may be called upon to use.
3. It is your responsibility to know that you have been properly trained in Firefighting and/or Emergency Response and in the use, precautions, and care of any equipment you may be called upon to use.
4. It is your responsibility to be in proper physical condition and to maintain the personal skill level required to operate any equipment you may be called upon to use.
5. It is your responsibility to know that your equipment is in operable condition and has been maintained in accordance with the manufacturer's instructions.
6. Failure to follow these guidelines may result in death, burns or other severe injury.



Fire and Emergency Manufacturers and Services Association, Inc.
P.O. Box 147, Lynnfield, MA 01940 www.FEMSA.org

Copyright 2006 FEMSA. All Rights Reserved

⚠ WARNING Read this manual before installing or operating the
COMMAND LIGHT SHADOW^{RTB}.
 Save this guide for future reference.

Contents

Warranty	4
Breakage or Damage During Shipment	5
Product Safety Precautions	6
General Description and Specifications	7
Operation	7
Raising the light from the nested position.....	7
Returning the light to the nested position.....	7
Autopark Sequence.....	8
Installation	9-11
Installation Kit.....	9
Tools Required.....	9
Installation Notes.....	10
Location Requirements.....	10
Mounting.....	11
Holster Mounting.....	11
Electrical Wiring	12
12 VDC.....	12
Warning Device Installation.....	12-13
Maintenance	14
Cleaning.....	14
Power Failure	14
Rotate to center.....	14
Retract the lower stage.....	14
Troubleshooting	15
Error Codes on Holster Circuit Board	16
Technical Specifications – 80" DC Model (SL442D)	17-18
Specifications.....	19
Parts Lists - Exploded Views	19-28
Exploded View (Base).....	20-21
Exploded View (Midplate).....	22-23
Exploded View (Lamp Tree).....	24-25
Backlight.....	26-27
Relay Box.....	28-29
Wiring Schematics	30-35
Relay Box.....	30
Holster Box.....	31-32
OPS Wireless Controller (VMUX/Wireless Systems).....	33
Contact Switch.....	34
Rotation Assembly.....	35



Command Light
3842 Redman Drive
Fort Collins, CO 80524

PHONE: 1-800-797-7974
FAX: 1-970-297-7099
WEB: www.CommandLight.com

COMMAND LIGHT 5 YEAR LIMITED WARRANTY

COMMAND LIGHT products* come with an industry leading 5-year warranty against any defects in materials and workmanship when used and operated for a period of five years. The responsibility of *COMMAND LIGHT* under this limited warranty is limited to the repair and replacement of parts found to be defective by *COMMAND LIGHT*.

Any parts damaged in shipping or by improper installation, overloading, abuse, or accident of any type or cause are not covered by this warranty. If equipment has been damaged in transit, a claim should be made against the carrier within three days, as we assume no responsibility for such damage.

If during this time period, you have any malfunctions not related to misuse, accident, neglect, or normal wear and tear, please take the following steps in order to have your light tower serviced under the *COMMAND LIGHT* warranty.

1. Contact us immediately for initial diagnosis at info@commandlight.com or **800-797-7974**; or if parts are needed contact parts@commandlight.com.
2. You will need to have immediate access to the light tower and the serial number. This process can be done by individuals with little mechanical ability. (Involves pushing buttons and telling us what the light tower is doing or not doing)
3. We then send parts (if needed) and have an authorized technician dispatched (if needed) with a written work authorization number and a base number of hours allotted to do repair. Hourly rates for service are to be determined at the time of authorization by *COMMAND LIGHT*, travel time is paid at a maximum of 50% of the authorized service rate.
4. We remain available for service support via phone, email, or video conference while the technician completes the repair, also to extend the original time allotted if additional issues arise. Immediate support cannot be guaranteed unless a time is scheduled prior to service.
5. Let us know when the repair is completed and reference the work authorization number. Email an invoice to info@commandlight.com or parts@commandlight.com. If you are unable to create an invoice email us for instructions for payment. Make sure any parts we have requested to be returned have been shipped back to the provided shipping address. If a return label is issued it must be used.

6. Finally, we will pay by mailing a check or crediting the account of the person, department, or company doing the repair. Payments will not be made until all requested parts have been returned.

Please contact us as soon as problems arise in order to execute our warranty. We must have knowledge of the issue and provide a work authorization in order to pay or reimburse labor or travel time.

Any unauthorized service voids this warranty. No work is authorized until written consent is provided by **COMMAND LIGHT**.

Contact Us Early — before any work is done — We'd love to help!

*Excludes light producing components (bulbs, lasers, LEDs) These components may come with their own manufacturer warranty. Contact us and we can help get it.

Breakage or Damage During Shipment

The transportation company is fully responsible for all shipping damage and will resolve problems promptly if you handle it correctly. Please read these instructions carefully.

Examine the contents of all shipping cases. If you find any damage, call your transportation agent at once and have them make a description on the freight or express bill describing the damage and the number of pieces. Then contact us and we will send you the original bill of lading. Also promptly contact the transportation company and follow their procedure for filing a claim. Each company will have a unique procedure to follow.

Please note, we cannot and will not enter claims for damages. If we a filed claim here, it would be sent to your local freight agent for verification and investigation. This time can be saved by you filing the claim directly. Every consignee is on the ground floor, in contact with the local agent who inspects the damaged goods, and thus, each claim can be given individual attention.

Since our goods are packed to comply with the regulations of all railroad, truck, and express companies, we cannot allow deduction from any invoice because of any damage, however, be sure to file your claim promptly. Our goods are sold F.O.B. factory. We take receipt from the transportation company certifying that the goods were delivered to them in good order and our responsibility ceases.

It is seldom that any breakage or damage occurs in any of our shipments and in no case will the customer be out any expense if they follow the above instructions.

Be sure to keep all damaged goods subject to examination of the truck or express company inspector, who may call on you sometime later. These damaged goods, of course, will belong to them, and they will inform you what to do with them. If you dispose of these damaged goods, your claim may not be paid.

WARNING

Product Safety Precautions

- ⊙ Never operate the *COMMAND LIGHT SHADOW^{RTB}* near overhead high voltage power lines. The *COMMAND LIGHT SHADOW^{RTB}* is manufactured from electrically conductive materials.
- ⊙ Do not use the *COMMAND LIGHT SHADOW^{RTB}* for uses other than its intended purpose.
- ⊙ Do not move emergency vehicle with the light extended. Visually verify that the light is completely nested before moving vehicle.
- ⊙ Do not change light position while people are located within its operating envelope. There are numerous pinch points that can cause serious bodily injury.
- ⊙ Do not use a high-pressure washer or subject the light to high volumes of water when cleaning.
- ⊙ Never use the *COMMAND LIGHT SHADOW^{RTB}* as a lifting device or mobile arm.
- ⊙ Do not use a *COMMAND LIGHT SHADOW^{RTB}* that has been damaged or is not fully functional, including non-working indicator lamps.
- ⊙ Never hold any part of the *COMMAND LIGHT SHADOW^{RTB}* with a hand or foot while it is in motion.
- ⊙ The *COMMAND LIGHT SHADOW^{RTB}* has numerous pinch points. Keep loose clothing, hands and feet clear of moving parts.

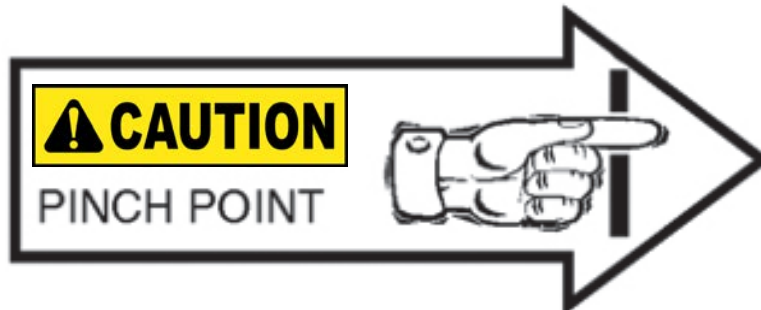
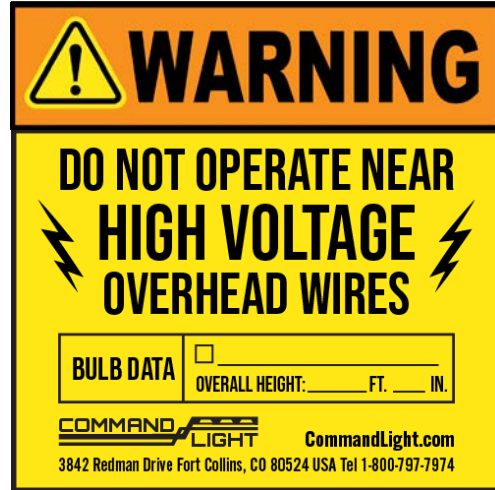

General Description and Specifications

The **SHADOW^{RTB}** is designed to provide high intensity emergency scene lighting with quick precision. As with any electromechanical device, take precautionary steps to ensure safe operation.

Model #	Description	Minimum Power Requirements
SL442D	4 x LED	90 Amps, 12 VDC

The vehicle provides power for the 12 VDC circuitry. A 15 Amp breaker is recommended. The umbilical corded control unit is powered via 12 VDC eliminating hazardous voltage levels within the hand held control box.

The **SHADOW^{RTB}** is manufactured to provide years of service with a minimum of maintenance.

Operation

Raising the light from the nested position



Using the control box, raise the lower stage. Control switches are of momentary action style and must be held in the “on” position to actuate the stages.

The **SHADOW^{RTB}** has an override system that precludes rotation of the lamp tree until the lower stage has elevated approximately 16" from the nested position. When the lower stage is below 16" the following conditions exist:

- Lamp Tree is prevented from rotating.
- All lights are turned off, including strobe light if equipped, regardless of light switch positions.
- Prevents the lower stage from moving down if lamp tree is not centered.



If the supply from the vehicle is marginal, position the **SHADOW^{RTB}** before turning on lights.

Returning the light to the nested position

The **KNIGHT²** is equipped with an Autopark function as a standard feature. The “P” button on the control box initiates the Autopark sequence. Once initiated, the “Emergency Stop”  button indicator is illuminated. Pressing the “Emergency Stop”  button will cancel the Autopark sequence.

Autopark Sequence

Press “P” button on the controller once. It does not need to be held in position. The Autopark sequence begins:

1. “Emergency Stop”  light is illuminated.
2. Lamps are extinguished.
3. Upper stage begins rotation to the center position. If equipped with back light option, back light begins oscillation and returns to the home position.
4. Once upper stage is centered, rotation stops, lower stage begins retracting.
5. After lower stage has fully retracted, the “Emergency Stop”  light turns off.

Controller

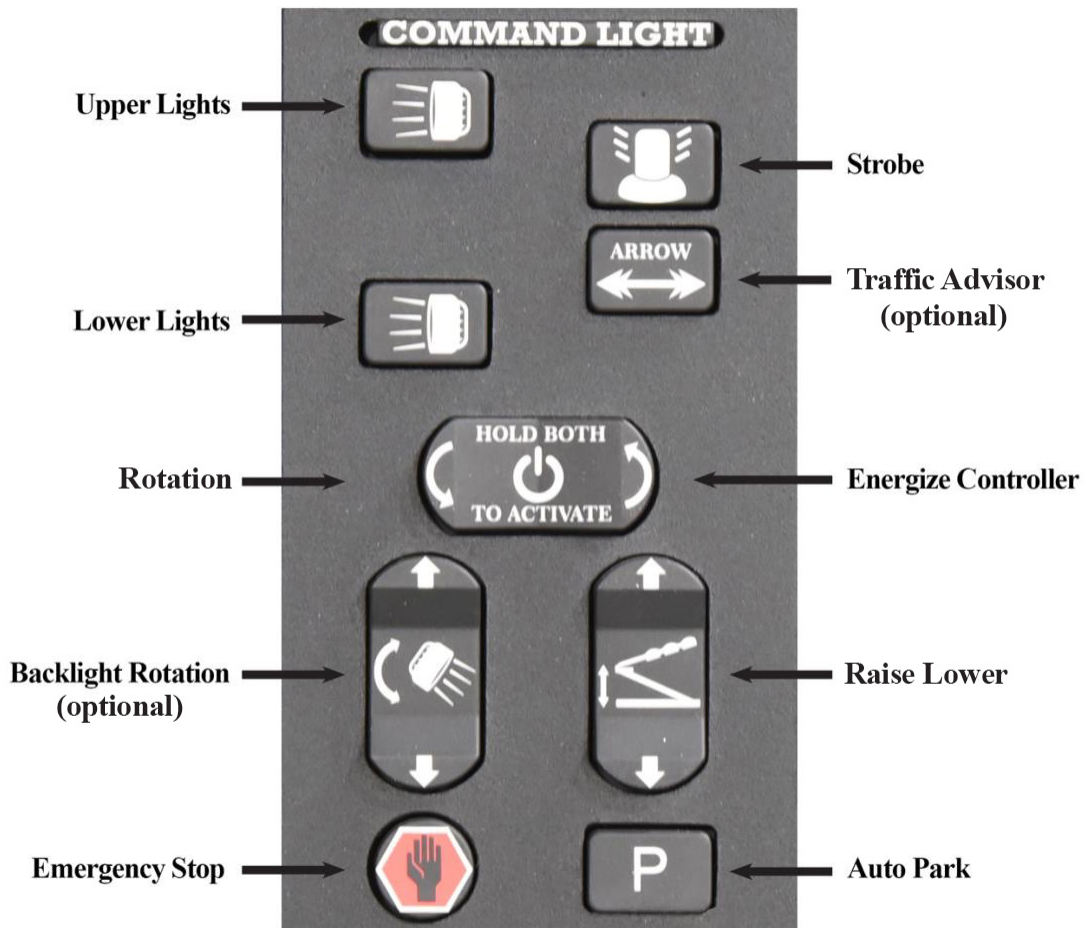

Installation

The **SHADOW^{RTB}** must be installed by a designated installation facility or by an EVT certified Level FA4 Technician. All safety precautions must be thoroughly understood before installation. Please consult the factory for additional installation information assistance.

Improper installation can cause overheating of electrical power wires that could catch fire and void the warranty.

Ensure all wiring is properly protected with correct sized breakers and fuses before connecting to the power source.

DC powered light towers require a high current draw to provide high levels of lighting. Verify all connected electrical components are able to handle the load for this light tower as listed in the Technical Specifications on page 17.

If in doubt, contact Command Light at 1-800-797-7974 or info@commandlight.com.

Installation Kit

Included with the **SHADOW^{RTB}** is an installation kit. Verify that the kit contains the following items:

- | | |
|--|--|
| (1) 25 feet of 2GA-2 Conductor power cable | (1) 25 feet of 22GA-20 conductor cable |
| (1) Pre-wired HOLSTER BOX w/cover | (1) Handheld Controller |
| (1) Small hardware parts bag with: | |
| (4) mounting spacers | (4) 5/16-18 X 2 1/2" bolts |
| (4) 5/16-18 nylon lock nuts | (8) 5/16" flat washers |
| (4) large diameter flat washers | (2) 1/4-20 x 5/8" Phillips pan head machine screws |
| (4) 1/4" flat washers | (2) 1/4-20 nylon lock nuts |
| (1) 1/2" 90° sealing connector w/nut | |

Tools Required

Lifting device (crane, forklift, block and tackle, etc.)
 Sling for lifting
 Drill
^{21/64"}, ^{17/64"} drill bits
 Hole punch for metal with ^{7/8"} and ^{15/16"} diameter capacity
 Phillips head screwdriver, #2
COMMAND LIGHT flat blade screwdriver (included with light)
^{7/16"} and ^{1/2"} combination wrenches and/or ratchet and ^{7/16"} and ^{1/2"} sockets
 8" adjustable wrench
 Tongue and Groove Pliers
 Wire stripper or razor blade knife
 Solder-less wire connector crimp tool
 Silicone based gasket sealer, RTVTM recommended

Installation Notes

CAUTION The *SHADOW^{RTB}* weighs approximately 115 pounds. Use mechanical assistance such as a forklift or crane to lift the light into installation position.

Use the provided fender washers under the mounting surface to distribute the weight load evenly.

When routing the connecting electrical wires take care to avoid sharp bends, hot components or other hazards to the wire.

The *SHADOW^{RTB}* is not designed to be operated in a raised position while the vehicle is in motion. The *SHADOW^{RTB}* includes warning circuit wiring to enable a warning device.

Location Requirements

The 80 inch *SHADOW^{RTB}* can be mounted on any location that is 66" x 22". The surface should be flat or have only a slight crown. For a recessed installation allow for a minimum of 94" x 43". Consult with factory before construction of recessed installation. Verify all dimensions before installation to assure proper operation of light will not infringe on other installed components. For all other installations refer to the dimensional drawing included on page 17 of this guide that represents your particular model of light. The drawings reflect the dimensions of the “working envelope” of a typical light. Endure sufficient clearances are incorporated in your installation to allow for variations (vehicle body flex, environmental conditions, future servicing needs, etc.)

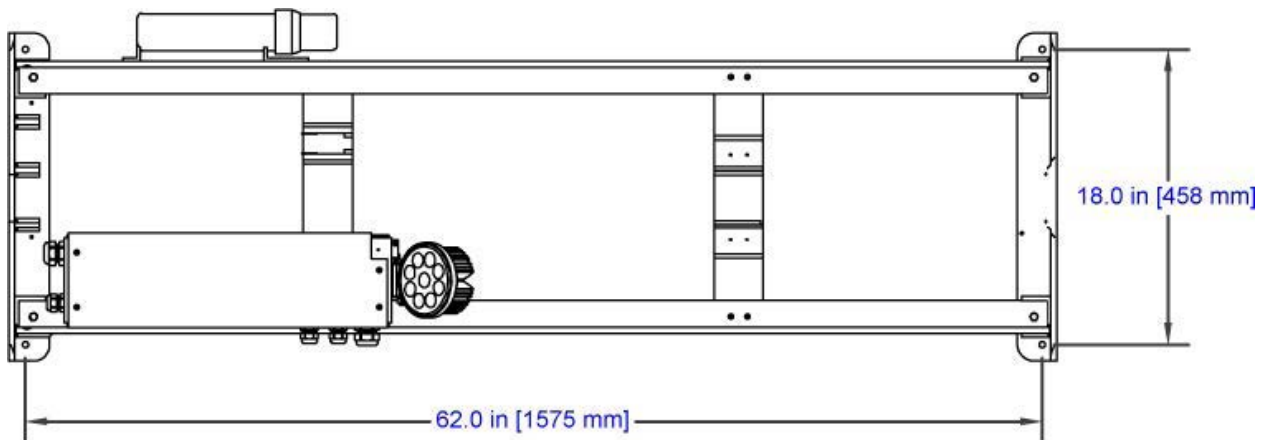

Four mounting bolts are required. Additional holes may be drilled in the frame ends if necessary to clear obstructions.

Access holes for the power cord cabling should be in close proximity to the entrance box on the light. Installing the cords with a sweeping 90° or 180° bend will provide better results.

The control box holster should be mounted in an area shielded from the weather. Allow a minimum of 10” clearance above the control box holster mounting location for easy access to the controller.

Mounting

Place the provided spacers in the location of the light mounting holes. The spacers may be modified to conform to the contour of the mounting location.

Remove any obstructions below the mounting surface such as headliners.

Attach any necessary lifting attachments to the **SHADOW^{RTB}**. The center of gravity (balance point) is slightly below the rotation assembly.

CAUTION Slowly lift the **SHADOW^{RTB}** and check for balanced lifting. Lower and make any necessary adjustments to the lift points.

Lift and place the **SHADOW^{RTB}** into position above the spacers. Before placing the full weight of the light tower on the spacers, align spacers with the holes in the end frame castings.

Drill $2\frac{1}{64}$ " holes in the mounting surface using the end casting holes as a template.

Fasten the light using the provided hardware. To assure a weather-tight installation apply a thin bead of silicone based gasket sealer to the base of the spacer and underside of bolt head.

Remove any lifting straps and devices from the **SHADOW^{RTB}**.

Locate and drill the wire feed holes.

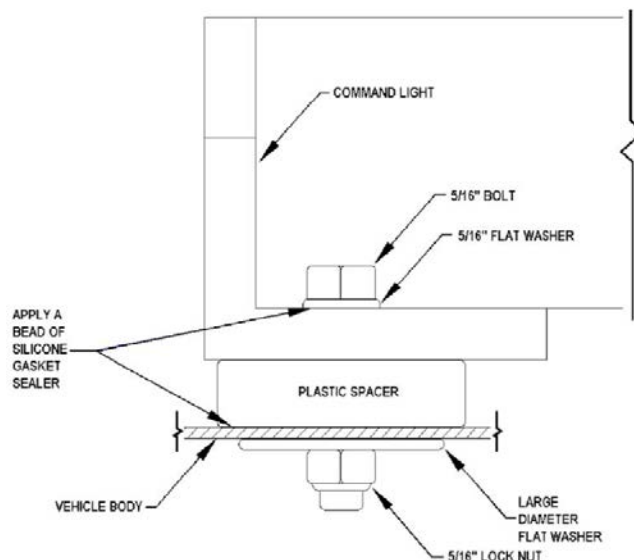

Control Box Holster Mounting

Using the holster as a template, mark locations of holes.

Drill $1\frac{7}{64}$ " mounting holes.

Drill any holes required to route the control wire from the control box to the **SHADOW^{RTB}**. Mount holster box with provided hardware.

Electrical Wiring

Please Note: Detailed internal wiring schematic for the light is found in the supplement pages found at the end of this document.

Run the control wire from the control box holster to the *SHADOW^{RTB}*.

Run the power wire from the breaker box or generator to the *SHADOW^{RTB}*. A 100 Amp breaker is recommended on DC models.

Make the control cable connections in the *SHADOW^{RTB}* relay box by matching each control wire to its same color on the connector block of the *SHADOW^{RTB}* relay box.

The *SHADOW^{RTB}* model SL442D comes pre-wired to connect to 12 VDC.

12 VDC

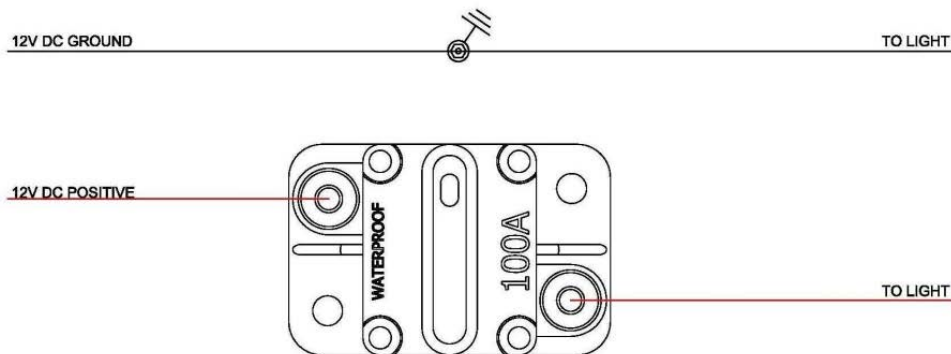

Warning Device Installation

The *SHADOW^{RTB}* nest sensor can be used to activate a warning device when the light is extended. Typically the vehicle will have a light or buzzer that activates when the compartment doors are open.

The connector for hooking up a warning device is located in the holster box that holds the control unit.

Warning Device Installation (Cont.)

Tools Required:

- $\frac{3}{32}$ " Flathead Screwdriver
- Wire Strippers
- Small Torch or Lighter



WARNING

Make sure Truck 12V power is OFF until wiring is complete at the holster circuit board and the light tower.

Incorrect wiring or live wires during install can cause damage to circuitry.

Wire the gray 22-20 control cable wires to the small connectors using the wiring schematics provided on pages 41 and 42. There are 2 different schematics, one is the standard version and the other is the version for dual control with wireless controllers or V-Mux control. The standard schematic will be used for V-Mux or any other multiplex system if it is only being used for elevated warning. A V-Mux wiring schematic and circuit board troubleshooting guide are included.

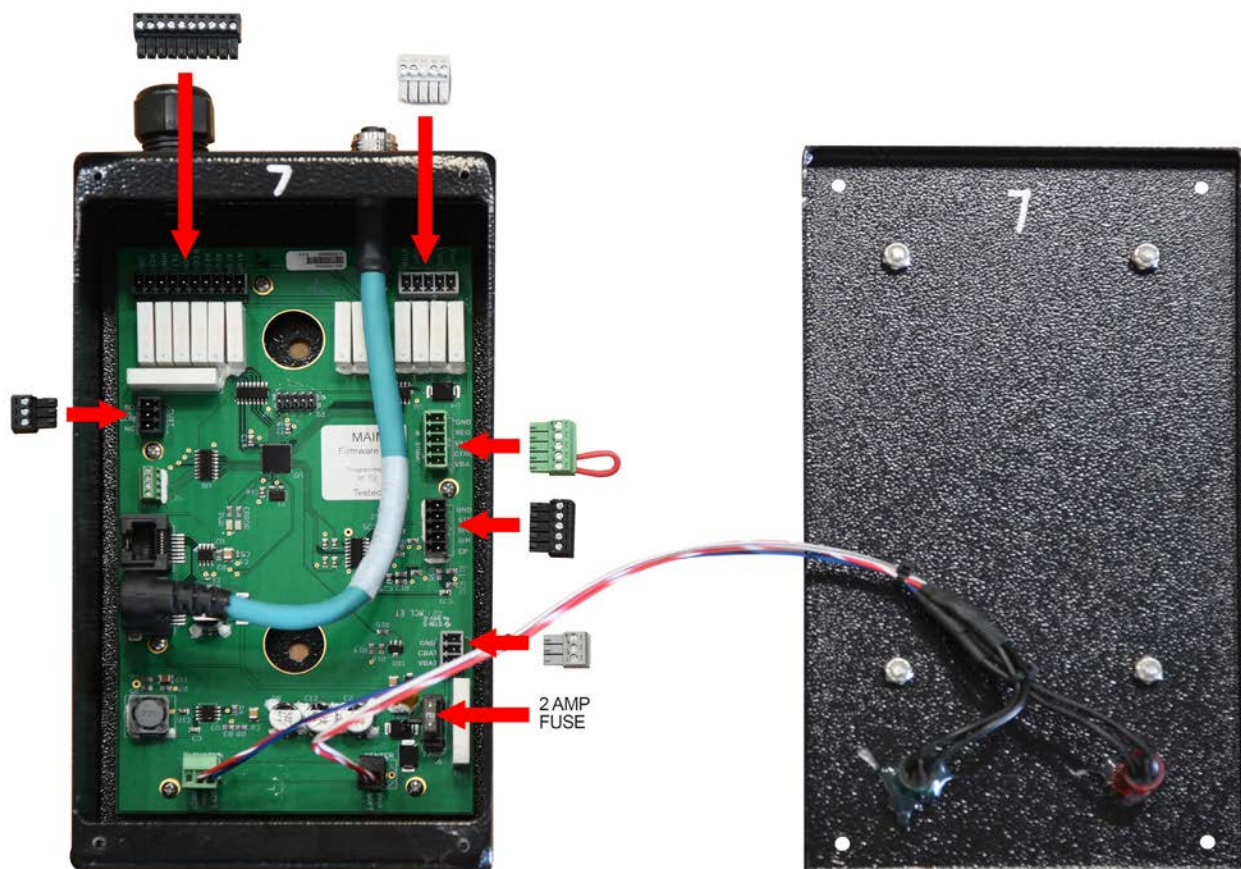

Detaching & Attaching the Controller



Make sure the tab on the coil cord connector lines up with the slot on the controller connector. Rotate the coil cord connector clockwise until finger tight. **DO NOT** use tools to tighten this connector.

Maintenance

Cleaning

The *SHADOW^{RTB}* is constructed with corrosion resistant aluminum and stainless steel fasteners. To further enhance corrosion resistance all exposed surfaces receive a powder coated paint finish. To assure years of trouble free service periodically clean all external surfaces with a mild detergent solution and a gentle spray of water. **DO NOT USE A HIGH-PRESSURE WASHER**, which will force water into sensitive electric circuitry.

Lamp lenses may be cleaned with any commercially available glass cleaner.

The lower stage actuator is a sealed unit and does not require adjustment or lubrication. They also have a slip-clutch to compensate for minor stroke tolerances at the limits of its travel as well as internal limit switches. The actuator may produce a ratcheting sound at each end of the stroke which is normal. The actuator should not be made to ratchet excessively, this can lead to premature actuator clutch failure.

All pivot points on the *SHADOW^{RTB}* are self-lubricating thermal polymer. Periodic cleaning with a moisture displacing cleaner and soft bristle brush, without disassembly, to remove accumulated dirt and debris will minimize wear.

Power Failure

The *SHADOW^{RTB}* can be retracted manually if power to the unit is lost. If power loss is temporary, reestablishing power may be easier than manually retracting the light.

 **WARNING** Disconnect power source from the *SHADOW^{RTB}*.

Retract the Lower Stage

Locate the silver plug located on the actuator below the actuator's motor. Use the provided hex tool (6mm hex bit) to remove silver plug. Be sure to not lose this plug. Use the same hex tool inserted into the opening to drive the internal gears of the actuator. Be sure to replace the silver plug after this actuator is fully retracted.



**SL SERIES: MANUAL LIGHT
TOWER LOWERING**

www.commandlight.com/technical-videos.com



Troubleshooting

Problem	Possible Cause	Solution
Unit will not extend	No power to the unit	Check power input connections. Ensure 100 Amp input breaker has not been tripped.
	Incorrect installation	Refer to installation instructions.
Upper stage will not rotate	Lower stage not raised above 16"	Raise lower stage higher.
	Rotation motor failure.	Consult with factory.
Lights will not illuminate.	Lower stage not raised above 16"	Raise lower stage higher.
	Circuit breaker tripped.	Check circuit breaker at power supply.
	No power to the unit.	Check power supply operation/output.
Unit will not nest	Lamp tree not centered	Raise lower stage higher than 16". Center lamp tree (green light illuminated)
	Unit being operated on a slope >5°.	Level Truck. If problem persists, rotate lamp tree to center, using a pike pole, hold unit centered while lowering to nest position.
Autopark button must be held in to park unit	Faulty or stuck nest switch.	Check nest switch ground and operation. Rubber boot may have shrunk and is holding in switch.
	Water in electronics.	Remove moisture from ground points and electronics. Do not use a pressure washer to clean unit.
No lights or rotation	Check safety limit sensor, bad, etc.	Contact factory for replacement part.
Autopark is off Center	Center switch out of alignment.	Contact factory for replacement part.



PWR AND ERROR LED GUIDE BOARD REV 5. MAIN BOARD 5.3, FIRMWARE 4

<p>PWR ON</p> <p>ERROR OFF</p>	<p>READY TO GO</p>
<p>PWR OFF</p> <p>ERROR OFF</p>	<p>NO POWER AND/OR NO GROUND AT EITHER CBAT OR VBAT TERMINALS CHECK VBAT, CBAT, AND GND TERMINALS. SHOULD HAVE 12-18 VDC</p> <p>CHECK 2 AMP FUSE AT MAIN BOARD</p>
<p>PWR FLASH 1X PAUSE FLASH 2X PAUSE REPEAT</p> <p>ERROR ON</p>	<p>ERROR CODE 12 NO CBAT POWER AT 3 PIN GRAY CONNECTOR "CBAT" TERMINAL, COMMAND LIGHT IS NOT POWERED. CHECK FOR 12VOLTS AT GRAY 3 PIN CONNECTOR, TERMINAL CBAT.</p>
<p>PWR FLASH 1X PAUSE FLASH 3X PAUSE REPEAT</p> <p>ERROR ON</p>	<p>ERROR CODE 13 COMMUNICATION ERROR BETWEEN MAIN BOARD AND KEYPAD BOARD. CHECK ALL CAT 5 CONNECTIONS BETWEEN THE MAIN BOARD AND THE KEYPAD BOARD INCLUDING COIL CABLE.</p>
<p>PWR FLASH 1X PAUSE FLASH 4X PAUSE</p> <p>ERROR ON</p>	<p>ERROR CODE 14: WILL ONLY ERROR ON FIRST LOGIN ATTEMPT AND DOES NOT REPEAT. YOU MUST LOOK FOR THIS ERROR CODE AS YOU ARE TRYING TO LOGIN TO THE DEVICE. INDICATES THAT COMMAND LIGHT CONTROLLER DOES NOT HAVE CONTROL OF THE SYSTEM. - IF USING VMUX - CHECK GREEN 5 PIN CONNECTOR "VMUX IF" FOR 12 VOLT POWER AT THE "CTRL" TERMINAL. IF NO, CHECK VMUX DUAL CONTROL BOARD.</p> <p>IF NOT USING VMUX, ENSURE BLACK/WHITE WIRE IS TERMINATED INTO THE CTRL TERMINAL AND THAT THIS TERMINAL HAS 12VDC.</p>

Technical Specifications – 80" DC Model (SL442D)

Dimensions (with strobe and ½" mounting spacers) – May vary by model and options:

	Height(Depth)	Length	Width
Retracted	9"	86"	35"
Extended	87"	89"	35"
Recessed installation	10"	94"	43" Minimum

Weight: 115 pounds

Wiring:

Main Power VDC	2/2 SO cord	25' provided
Control wiring	22/20 PVC Jacketed	25' provided

Relay protection:

Lights	Cole-Hersey	3055	100 amps
--------	-------------	------	----------

Current Draw / Power Requirements:

Fixture	Average
150 Watt LED	12 VDC/70 amps
220 Watt LED	12 VDC/90 amps

Lift actuators and rotation motor will cause higher current draw during use.

Motor Duty Cycle:

(All motors thermally protected, specifications are to thermal relay trip):

Lower stage 1:3 (90 seconds maximum per 5 minutes)

Rotation 5-6 Revolutions

Motor Speed:

Lower stage 0.5 inches per minute 14 seconds to full extension

Rotation 2.75 RPM at lamp tree

Operation:

Angle of vehicle 15° maximum incline

Specifications

SHADOW RTB

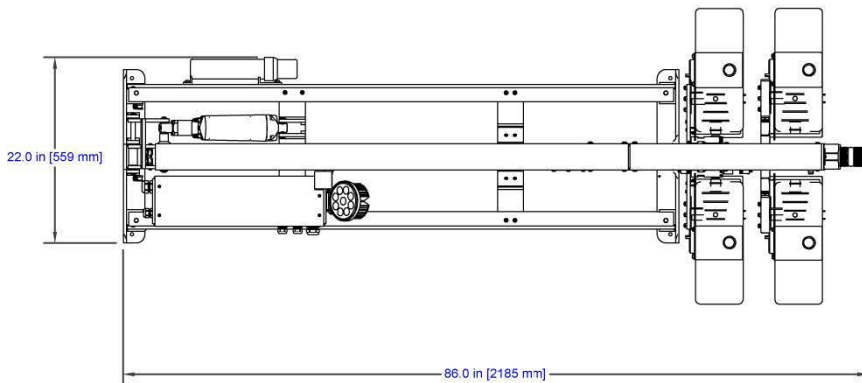
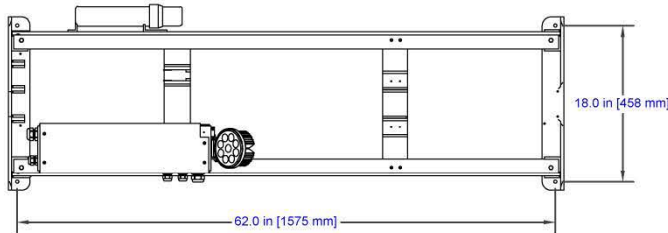
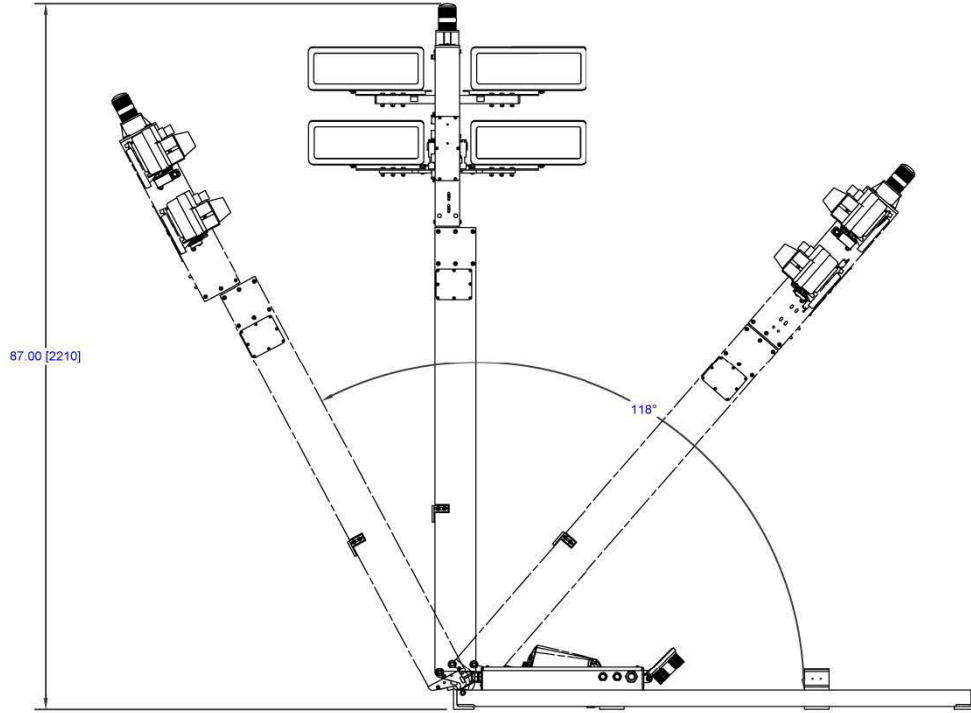

MINIMUM CLEARANCES FOR CONTROL & HOLSTER INSTALLATION

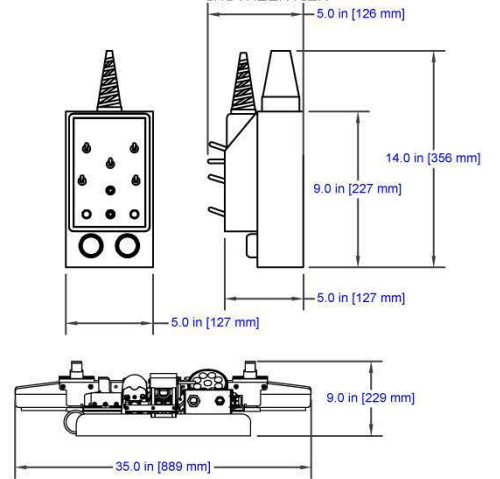

EXPLODED VIEWS AND WIRING SCHEMATICS

Parts List - (Base)

PARTS LIST			
ITEM	QTY	PART NUMBER	DESCRIPTION
1	1	178-01200	FRAME,WELDMENT,SHADOW RTB80
2	1	069-15407	ACTUATOR,LINER,150MM,12VDC,LA36
4	1	RTB_Rotation_ECO2	
5	1	178-02400	ARM, MAIN LIFT, WELDMENT,SHADOW RTB80
6	1	178-01015	MOUNT,LOWER ACTUATOR,WELDMENT
7	1	078-01025W	LIFTARM GUIDE, SHADOW RT, RTB 80
8	1	178-01501	PIN,LOWER,ACTUATOR,SHADOW RTB
9	1	178-01500	PIN,UPPER,ACTUATOR,SHADOW RTB
10	1	178-01502	PIN,LOWER,PIVOT,SHADOW RTB
11	1	178-01007	ARM,CROSS BRACE,LIFT,SHADOW RTB
12	1	178-01008	ARM,TRAILING,LIFT,SHADOW RTB
13	1	178-02097	COVER,ACCESS PANEL,LIFT ARM,SHADOW RTB
14	1	024-10527	PAD, 1/2 X 1 X 2, RUBBER
15	1	065-15000	CANISTER,DOCUMENT,BLACK
17	2	STD HARDWARE-LC	CLAMP,LOOM,#4,SS
18	2	065-12365	CLAMP,LOOM,#6,SS
19	5	STD HDW-JFI-0809-06	BEARING,FLANGED,IGLIDE,JFI-0809-06
20	6	SSER-22	E-Ring, 5133-50, .044T, SS
21	2	Pad_White	
22	8	STD HARDWARE BHM43	SCREW,BH,HEX,6x1x20,SS
23	22	STD HARDWARE LW2	WASHER,LOCK,SPRING,REGULAR, M6, SS
24	2	STD HARDWARE BHM42	SCREW,BH,HEX,6x1x16,SS
25	2	069-01126	Nut, MS, M8x1.25
26	3	STD HARDWARE-SHCSM36	SCREW,SHCS,SHCS M4x0.7x12
27	14	STD HARDWARE BHM39	SCREW,BH,HEX,6x1x10,SS
28	4	STD HARDWARE-PHP-74	SCREW,PHP,MS,1/4-20UNCx1/2,SS
29	2	STD HARDWARE W21	WASHER,FLAT,USS, 1/4", SS
30	4	STD HARDWARE-FHMS-63	SCREW,FHPMS,8-32 UNC x 7/16 in,SS
31	2	STD HARDWARE BHM15	SCREW,BH,HEX,4x0.7x12,SS
32	8	STD HARDWARE BHM12	SCREW,BH,HEX,4x0.7x6,SS
33	8	STD HARDWARE LW1	WASHER,LOCK,SPRING,REGULAR, M4, SS
35	1	Relay box assembly	
36	1	178-02210	BUSHING,PIVOT,LIFT ARM,SHADOW RTB

Exploded View - (Base)

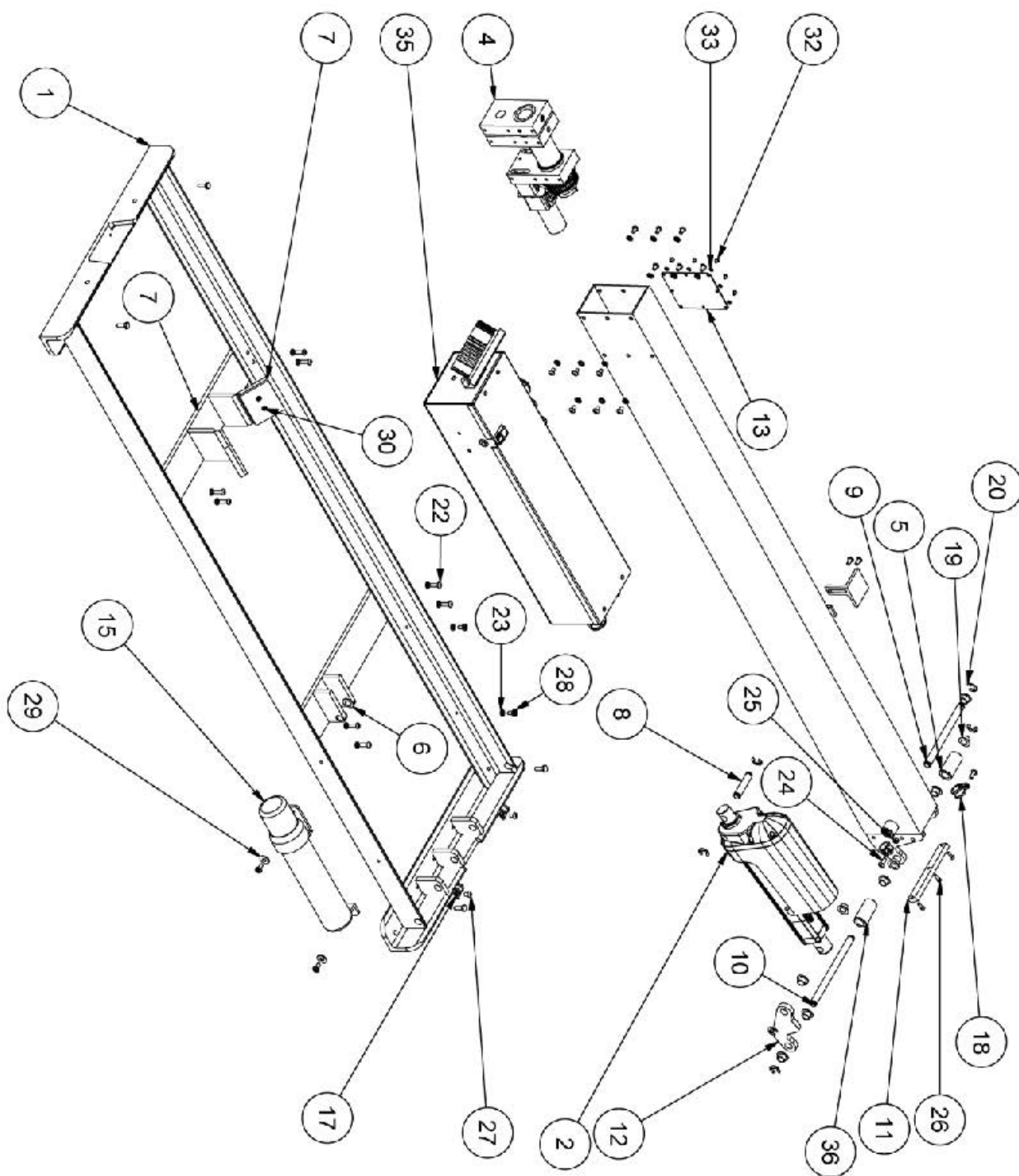

Parts List - (Mid-Plate)

PARTS LIST			
ITEM	QTY	PART NUMBER	DESCRIPTION
1	1	178-03002	PLATE, ROTATION DRIVEN, SHADOW RTB
2	1	069-01103	SCREW,SHCS,SHCS M6x1x12
3	5	034-13683	SCREW,SH SET,M6x1.0 x 16mm,SS
4	1	178-03010	BEARING,THRUST,ROTATION,SHADOW RTB
5	1	065-12382	RING,SPIROLOX,2-TURN,WS-175
6	1	178-03001	PLATE, ROTATION DRIVE, SHADOW RTB
7	2	178-03006	STANDOFF,MOTOR,ROTATION,SHADOW RTB
8	1	178-04084	MOUNT,MOTOR,ROTATION,SHADOW RTB
9	4	034-13063	SCREW,SHCS,SHCS M4x0.7x30
10	1	034-13066	SCREW,SHCS,SHCS M4x0.7x10
11	1	178-03005	STOP,ROTATION LIMIT,SHADOW RTB
12	2	065-12383	SWITCH,LIMIT,CHERRY,SPDT,5A,125V,SRTBL
13	4	034-03070	SCREW,PHP,2-56 UNCx0.5
14	1	178-03007	LARGE PULLEY,MID PLATE,SRTBL
15	1	178-03009	CAM,ROTATION CENTER,SHADOW RTB
16	1	069-01133	SCREW,BH,HEX,M4x0.7x10,SS
17	1	178-04077	SWITCH,LIMIT,MIDPLATE,RTB
18	1	034-13092	SCREW,PPH,M4 X 8
19	2	065-12384	BUSHING,BRONZE,1.753 x 2.004 x 1,SRTBL
20	1	178-03003R3	SPINDLE,ROTATION W/BUSHING,SHADOW RTB
21	1	069-14229	SWITCH,SPDT,5A,250V,ON-MOM,QC
22	4	034-11211	WASHER,FLAT,SAE, #4, SS
23	2	034-11216	SCREW,HH,4-40x3/4,SS
24	2	034-13672	NUT,NYLOCK, 4-40 UNC,SS
25	1	069-01015	MOTOR,TRANSMOTEC,PDS4265-12-864-BF
26	1	065-12378	PULLEY,HTD,P5mm,W15mm,G17,DF,B8mm
27	1	065-12375	BELT,HTD,P5mm,W15mm,G053,SRT BL
28	1	034-13079	PIN,SPRING,5/32 x .75
29	1	034-10936	SCREW,SHS,8-32 UNC x 1/4,SS
30	1	178-03011	MIDPLATE, ROTATION, SHADOW RTB
31	4	034-10947	WASHER,FLAT,SAE, #8, SS
32	4	034-11175	WASHER,LOCK,SPRING,REGULAR, #8, SS
33	9	069-01139	SCREW,SHCS,SHCS M4x0.7x12

Exploded View - (Mid-Plate)

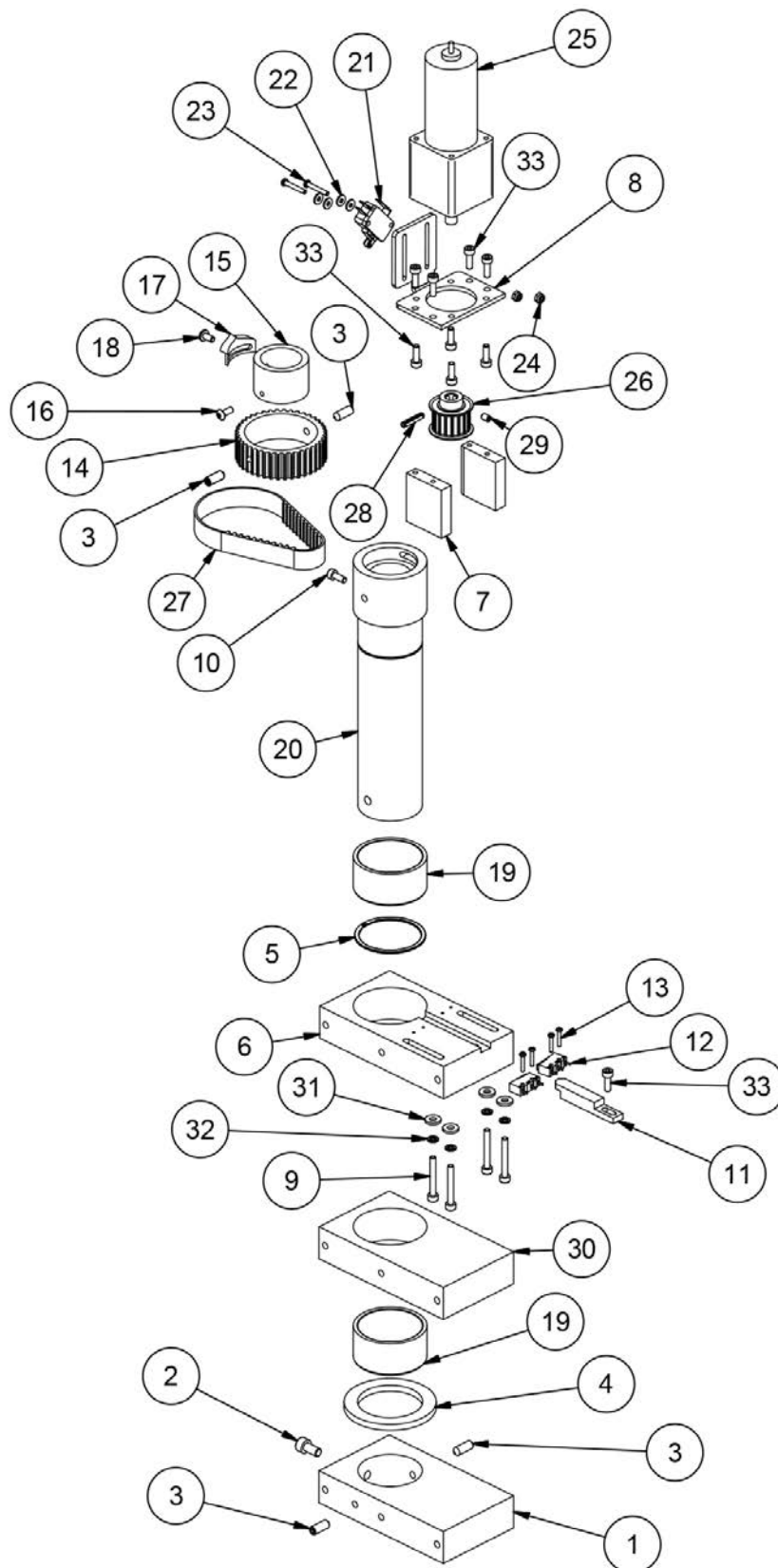

Parts List - (Lamp Tree)

ITEM	QTY	PART NUMBER	DESCRIPTION
2	2	178-445FIXT	LAMP,SUBASSEMBLY,BACKLIGHT,STD,SHADOW RTB
3	2	178-445FIXT	LAMP,SUBASSEMBLY,FIXED,STD,SHADOW RTB
9	8	034-11033	NUT,NYLOCK, 1/4-20 UNC,SS
10	1	178-04000	TREE,BARE,WELDMENT,SHADOW RTB
11	1	178-05100	MOUNT, STROBE, SHADOW RTB, WELDMENT
12	1	178-04017	MOUNT,LEFT,BACKLIGHT,SHADOW RTB
13	1	178-04018	MOUNT,RIGHT,BACKLIGHT,SHADOW RTB
14	1	RTB_BL_Assembly	
15	1	065-12867	STROBE, PRE-WIRED, INDICATE COLOR
16	2	034-13092	SCREW,PPH,M4 X 8
17	4	069-01103	SCREW,BH,HEX,6x1x12,SS
18	1	178-04009	COVER,ACCESS,LAMP TREE,SHADOW RTB
19	10	034-11028	WASHER,LOCK,SPRING,REGULAR, 1/4", SS
20	6	069-01102	SCREW,BH,HEX,4x0.7x12,SS
21	6	069-01140	SCREW,BH,HEX,6x1x16,SS
23	2	065-12851	STRAIN RELIEF,DOMED 90,SCR .39-.55,1/2 NPT,BLACK
24	1	069-15392	CONXALL, MINICON, 2 PIN, PANEL
25	2	065-12373	PLUG,FINISHING,1x2,SRT-BL,ROM CL
26	4	034-13062	SCREW,SHCS,SHCS M4x0.7x25
28	2	069-01125	Nut, MS, M4x0.7
29	1	065-12827	STRIP, BARRIER, 12 POLE
30	2	034-13288	SCREW,PHP,4-40 UNCx0.75
31	2	034-14283	WASHER,LOCK,18-8SS,INTERNAL,#4
32	2	034-10902	NUT,MS,HEX2,4-40UNC,SS
33	1	034-10975	SCREW,FHPMS,10-24 UNC x 3/4 in,SS
34	1	078-03013	SPACER,DIN RAIL,STROBE MOUNT
35	1	069-01000	RAIL, DIN, SLOTTED, 7.5MM X 35MM 4 in.
36	1	034-13081	NUT,NYLOCK,THIN, 10-24 UNC,SS
37	2	065-10075	BRACKET,END,DIN,DN-EB35
38	1	065-10069	BLOCK,TERMINAL,DIN,DN-T10-BLACK
39	1	065-10068	BLOCK,TERMINAL,DIN,DN-T10-BLUE
40	1	065-10073	BLOCK,TERMINAL,DIN,DN-T10-WHITE
41	1	065-10074	BLOCK,TERMINAL,DIN,DN-T10-YELLOW
42	2	065-10070	BLOCK,TERMINAL,DIN,DN-T10-GREEN
43	1	065-10068	BLOCK,TERMINAL,DIN,DN-T10-BLUE/WHITE
44	1	069-01134	SCREW,BH,HEX,M4x0.7x16,SS
45	1	069-01133	SCREW,BH,HEX,M4x0.7x10,SS

Exploded View - (Lamp Tree)

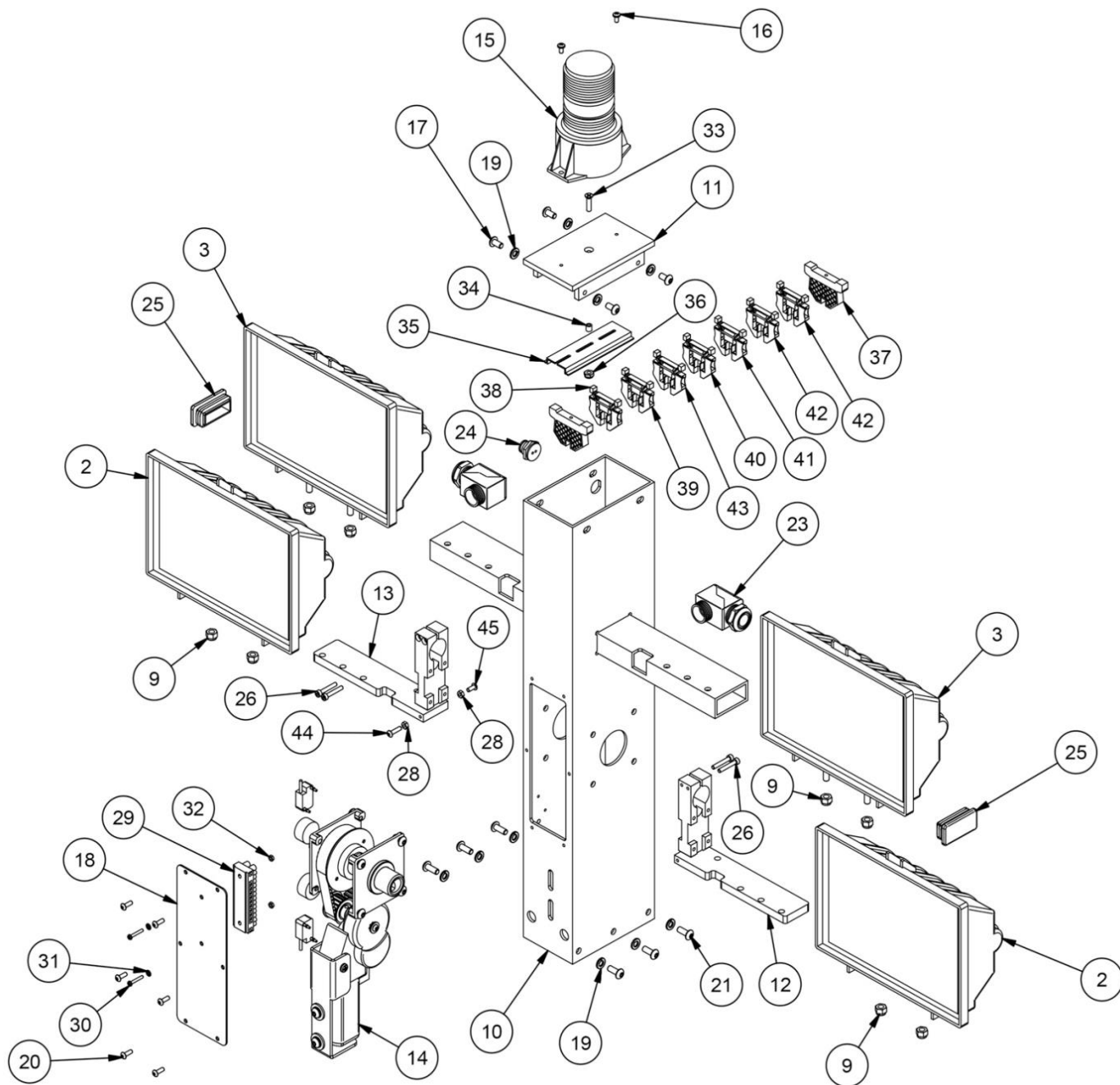

Parts List - (Backlight)

PARTS LIST			
ITEM	QTY	PART NUMBER	DESCRIPTION
1	2	178-04002	SUPPORT,SHAFT,PIVOT,SHADOW RTB
2	1	178-04004	SHAFT,DRIVEN,SHADOW RTB
3	2	MFI-1620-10	BUSHING,FLANGED,IGLIDE,MFI-1620-10
4	1	178-04003	PULLEY,HTD,SRT BACK LIGHT,RAW
5	1	178-04016	SHIM,SPACER,BACKLIGHT,SHADOW RTB
7	1	065-12374	MOTOR,THRU HOLE,12 VDC
8	1	178-04010	SHAFT,STUB,DRIVE,SHADOW RTB
9	1	065-12378	PULLEY,HTD,P5mm,W15mm,G17,DF,B8mm
10	1	065-12376	BELT,HTD,P5mm,G55,SRT BL
11	2	178-04007	STOP,ROTATION,BACKLIGHT,SHADOW RTB
12	2	069-01140	SCREW,BH,HEX,6x1x16,SS
13	2	034-11029	WASHER,FLAT,USS, 1/4", SS
14	2	034-11028	WASHER,LOCK,SPRING,REGULAR, 1/4", SS
15	2	STD HARDWARE-IEW-52	WASHER,LOCK,18-8SS,EXTERNAL,1/4in
16	1	STD HARDWARE-PHP-49	SCREW,PHP,MS,10-24UNCx1-3/4,SS
17	1	034-10981	NUT,NYLOCK, 10-24 UNC,SS
18	1	069-01133	SCREW,BH,HEX,M4x0.7x10,SS
19	1	034-11124	WASHER,FLAT,FENDER, 10 X 11/16, SS
20	1	034-10947	WASHER,FLAT,SAE, #8, SS
21	1	034-11175	WASHER,LOCK,SPRING,REGULAR, #8, SS
22	8	069-01103	SCREW,BH,HEX,6x1x12,SS
23	2	069-14160	SENSOR,PROXIMITY,4-WIRE
24	4	STD HARDWARE--07	SCREW,PHP,2-56 UNCx0.75
25	4	STD HARDWARE-N-001	NUT,MS,HEX1,2-56UNC,SS
26	1	178-04024	GUARD,BELT,BLIGHT,SHADOW RTB
27	1	065-12380	RING, RETAINING,1" STAINLESS STEEL
28	1	178-04027	MOUNT,MOTOR,DRIVE,AERIAL

Exploded View - (Backlight)

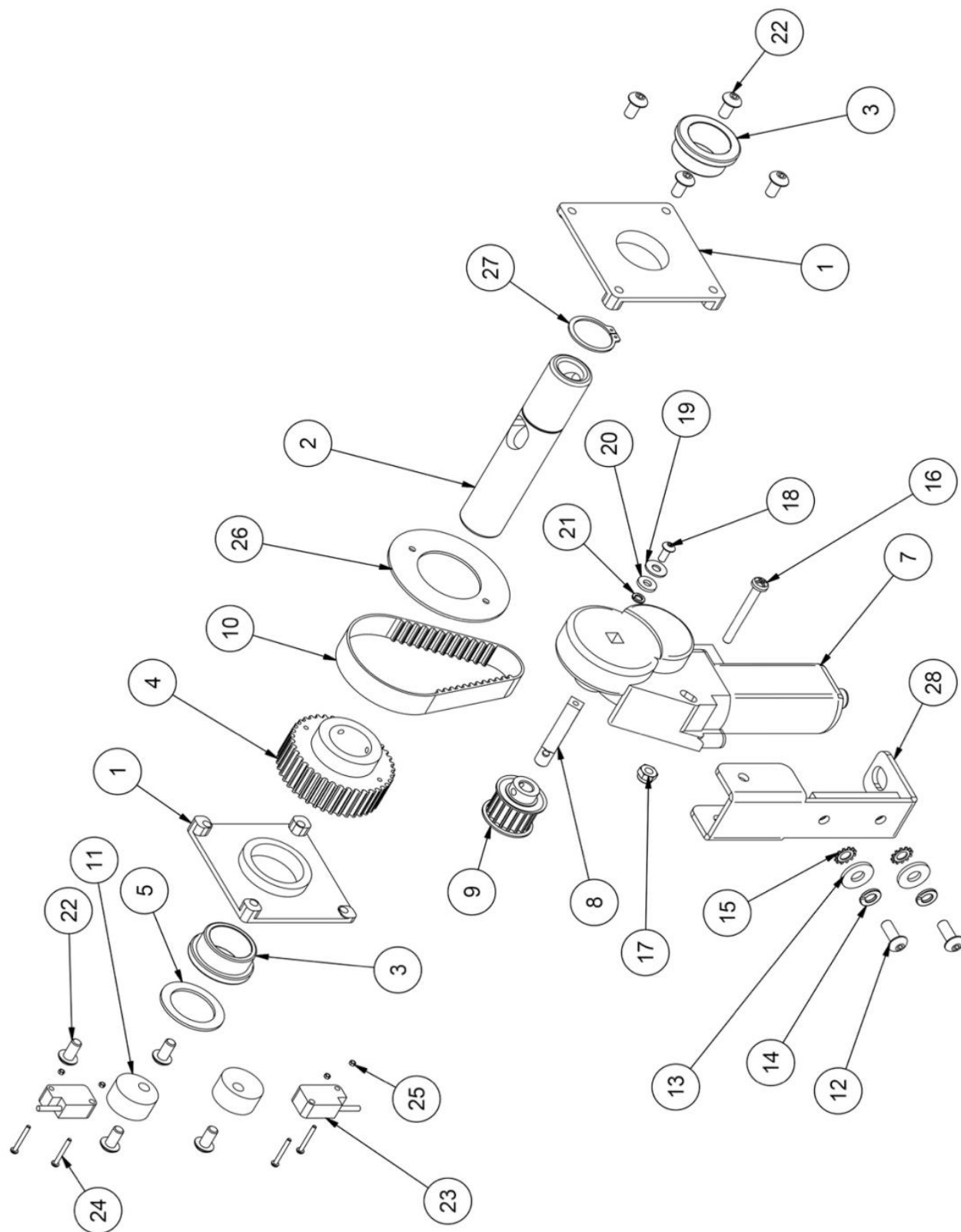

Parts List - DC Relay Box

PARTS LIST			
ITEM	QTY	PART NUMBER	DESCRIPTION
1	1	178-04075W	WELDMENT, RELAY BOX EXT., SHADOW RTB
2	1	065-14784	LOOKUP LIGHT,LED, KNIGHT,SHADOW
3	2	065-12854	STRAIN RELIEF,DOMED,SCR .51-.71,3/4 NPT,BLACK
4	3	065-12852	STRAIN RELIEF,DOMED,SCR .24-.47,1/2 NPT,BLACK
5	2	065-12857	LOCKNUT,NYLON,3/4 NPT,BLACK
6	3	065-12856	LOCKNUT,NYLON,1/2 NPT,BLACK
7	1	178-04076	BRIDGE, ELECTRICAL, RELAY BOX, RTB
12	1	065-13507	BREAKER,100 AMP,MANUAL RESET
15	2	065-12828	TERMINAL STRIP,16 POLE
16	6	034-10919	SCREW,PHP,6-32 UNCx0.75
17	6	034-11162	NUT,MS,HEX2,6-32UNC,SS
19	1	079-00005	PLATE,RELAY MOUNT,ALL
20	2	034-10966	SCREW,PHP,10-24 UNCx0.75
21	6	034-10978	WASHER,LOCK,18-8SS,INTERNAL,#10
22	2	034-13100	NUT,MS,HEX2,10-24UNC,SS
23	6	034-10961	SCREW,PHP,10-24 UNCx0.375
24	6	034-10981	NUT,NYLOCK, 10-24 UNC,SS
26	1	065-14187	RELAY SOCKET,3A,14 PIN,SRT BUILDS
27	1	065-14186	RELAY,BL,AUTO PARK,CL,SRT,MY2KDC12
28	2	034-11187	SCREW,FHPMS,6-32 UNC x 3/4 in,SS
29	2	034-13098	NUT,NYLOCK, 6-32 UNC,SS
30	1	065-13529	BREAKER, 12V 20A, SINGLE POLE
31	22	065-13730	Socket, Single Pole, Relay
32	22	065-13738	RELAY, 12V, SINGLE POLE
33	12	034-10939	SCREW,PHP,8-32 UNCx0.5
34	12	034-10951	NUT,NYLOCK, 8-32 UNC,SS
35	1	065-12890	STRIP, BARRIER, 20 POLE
36	4	034-13682	WASHER,LOCK,18-8SS,INTERNAL,#6
37	1	034-13690	SCREW,PHP,1/4-20 UNCx1.25
38	3	034-10110	WASHER,LOCK,18-8SS,INTERNAL,1/4in
39	3	034-11112	NUT,MS,HEX2,1/4-20UNC,SS
41	1	065-12792	STRAIN RELIEF,DOMED,SCR .71-.98,1 NPT,BLACK
42	1	065-12791	LOCKNUT,NYLON,1 NPT,BLACK
43	1	178-04074	COVER,RLY BOX,SHADOW RTB, EXTENDED
44	1	034-11016	SCREW,HH,1/4-20x3/4,SS
45	1	034-11028	WASHER,LOCK,SPRING,REGULAR, 1/4", SS
46	4	034-10968	SCREW,PHP,10-24 UNCx1
47	1	069-15360	SWITCH, DOWN LIMIT / NEST / BL LIMIT
48	1	065-12935	BOOT,PUSHBUTTON,BLK,BACK LIGHTS
49	3	069-15360	NUT,SWITCH, DOWN LIMIT / NEST / BL LIMIT

Exploded View - DC Relay Box

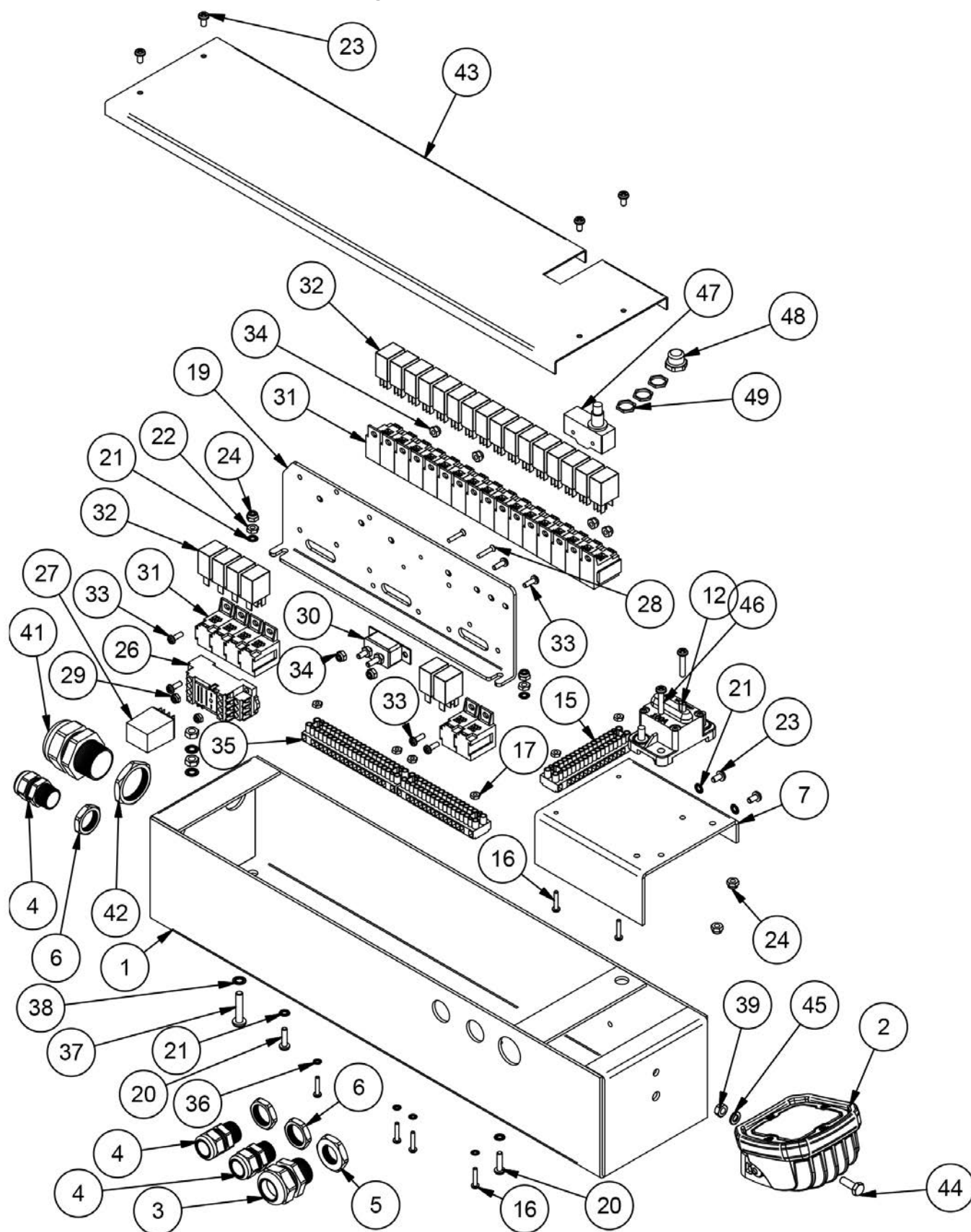

Wiring Schematics

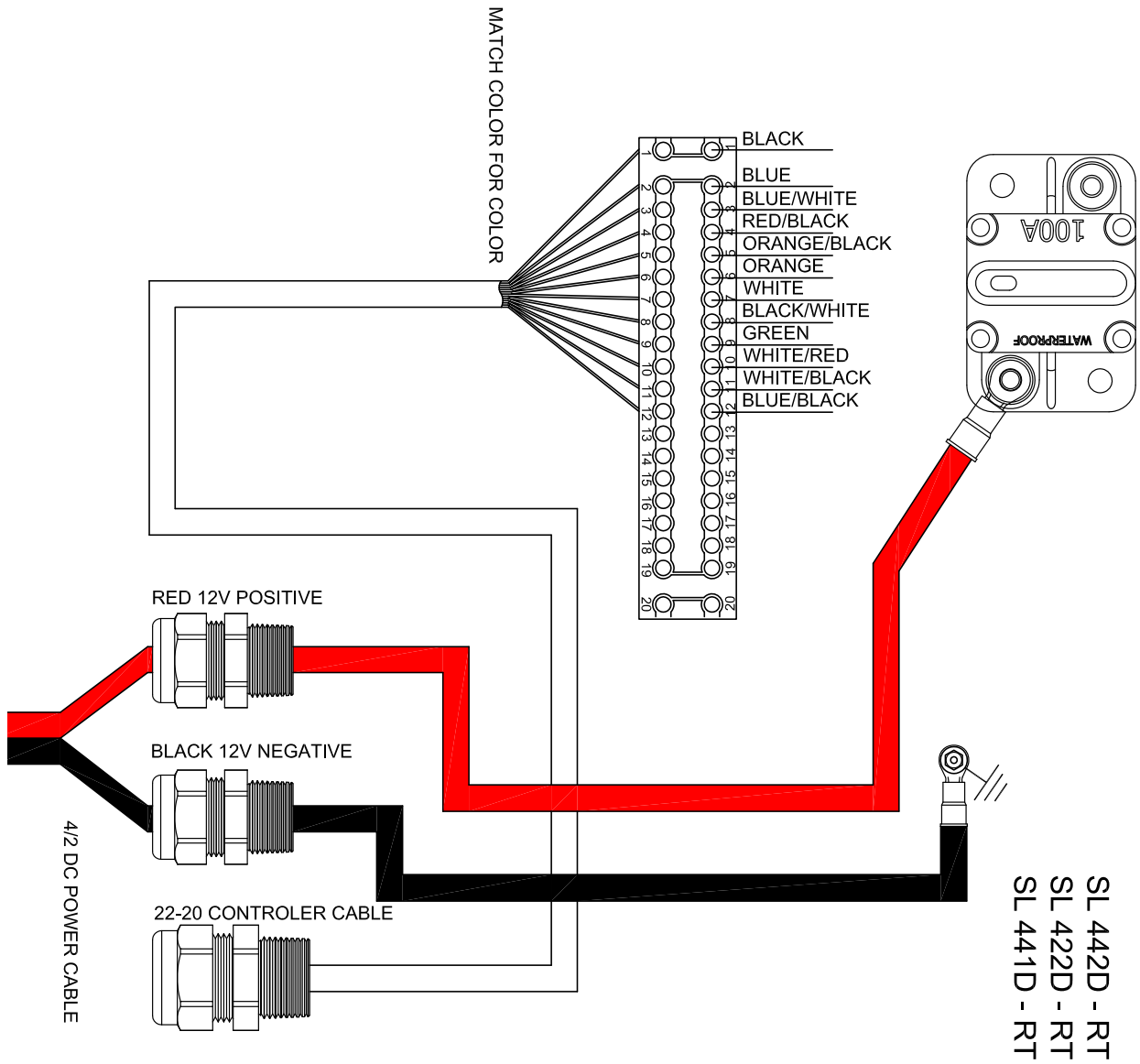

END USER HOOK-UP DIAGRAM

Holster Box

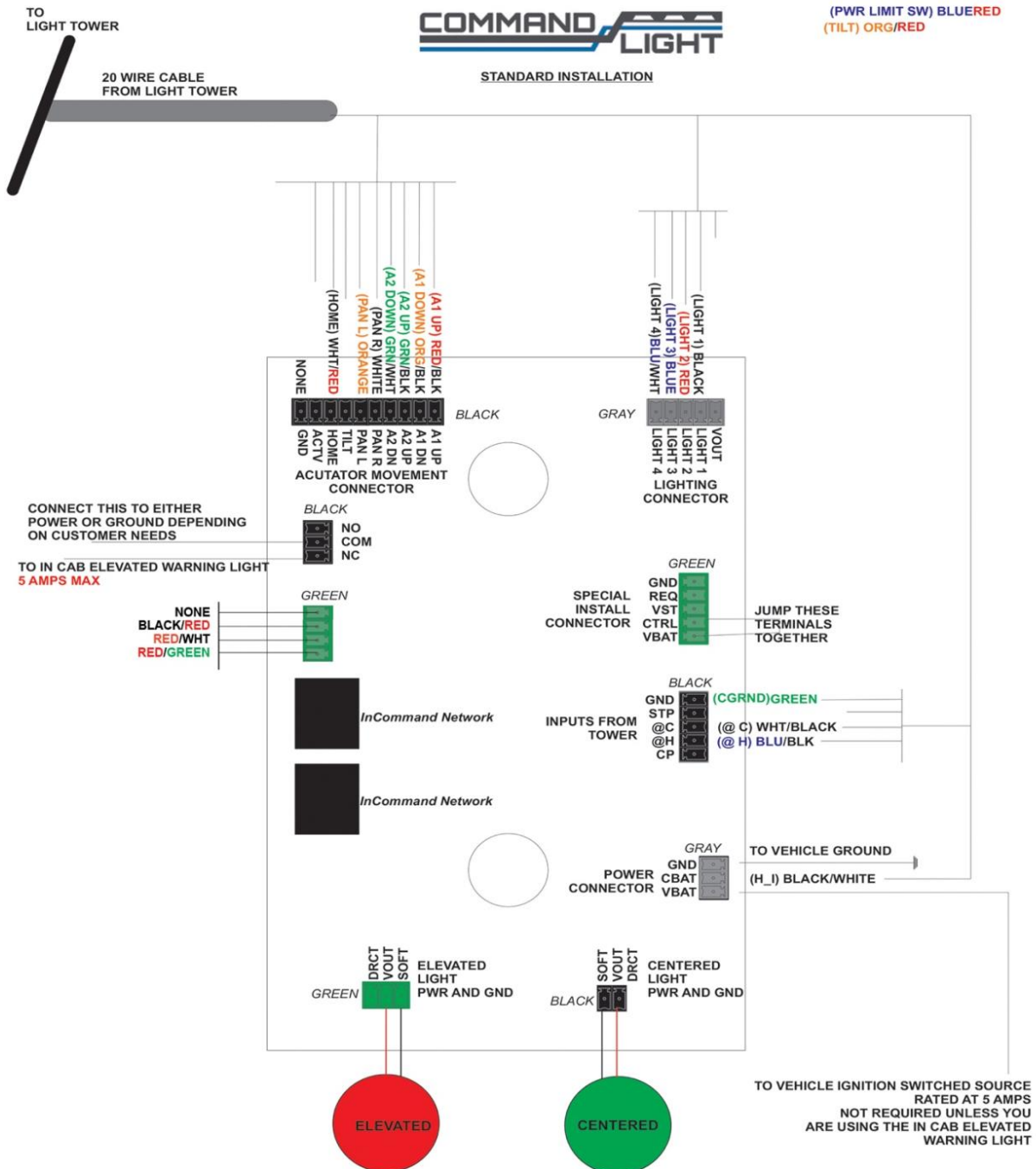

FOR USE WITH ALL SHADOW MODELS
MAIN BOARD REV SHADOW 5.4, DIAGRAM REV 1

Holster Box

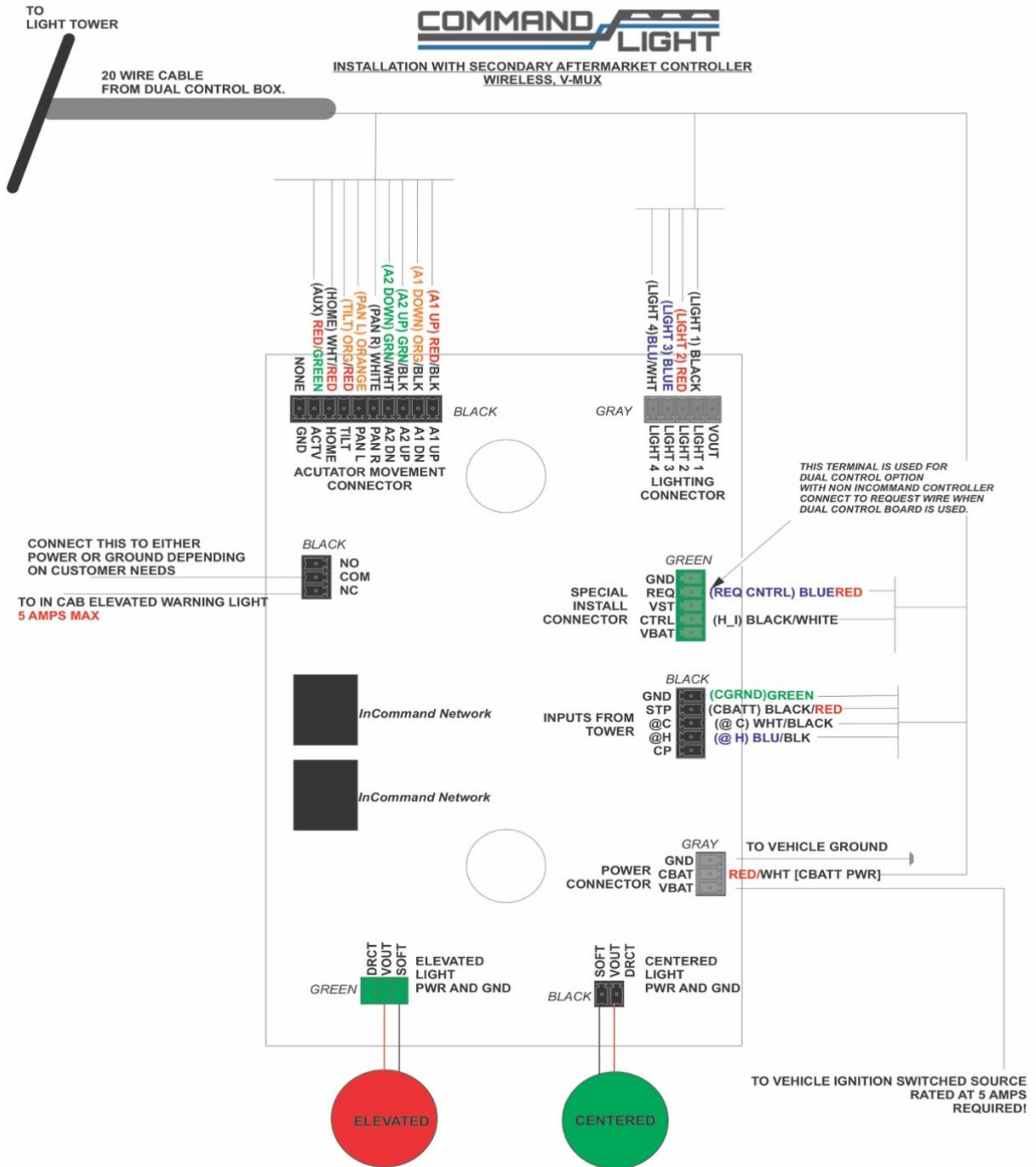

FOR USE WITH ALL COMMAND LIGHT MODELS
MAIN BOARD REV 5.4, DIAGRAM REV 3

OPS WIRELESS CONTROLLER

STANDARD

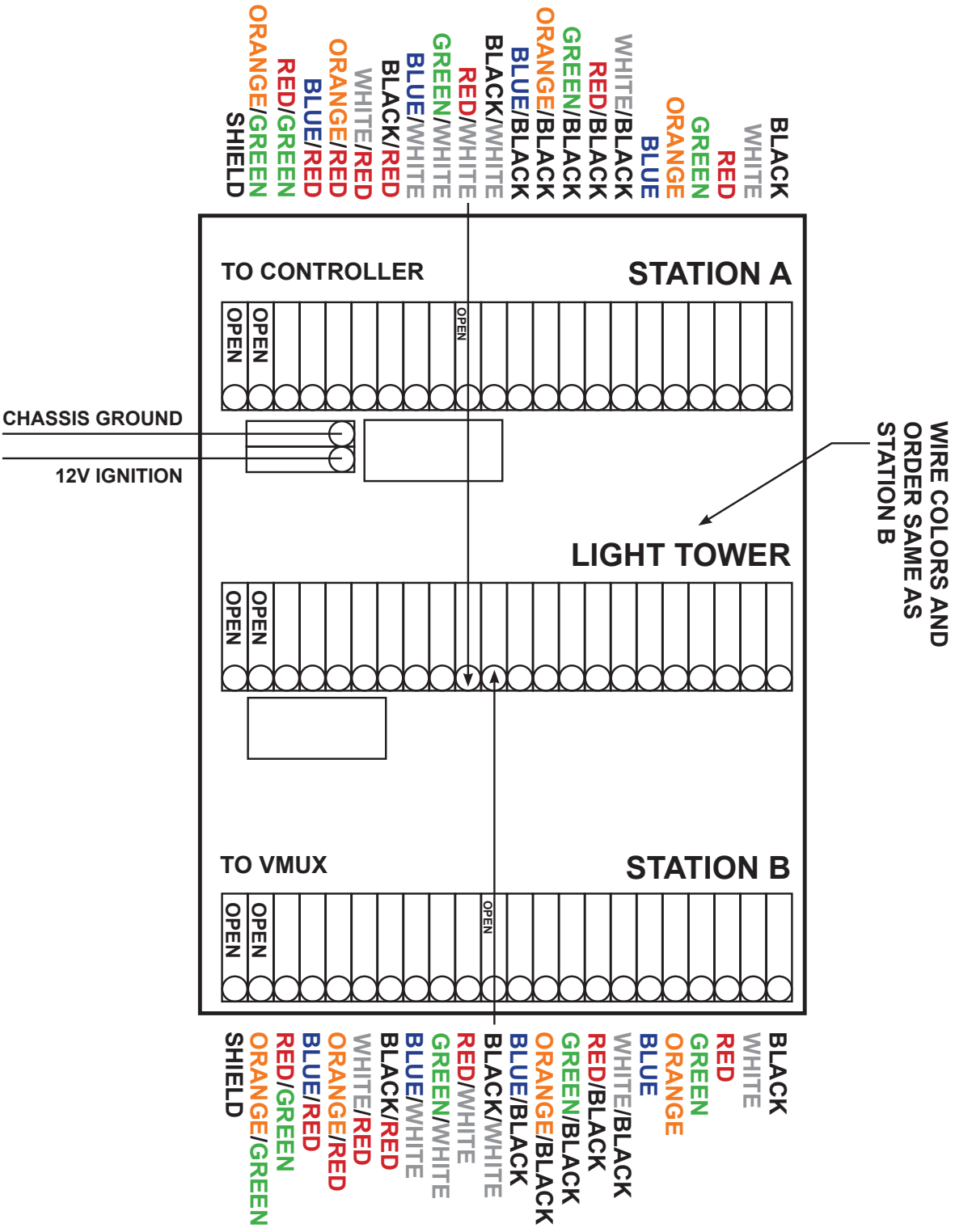

DC SHADOW RTB RELAY BOX 24V - WIRE SCHEMATIC
REV 02/21

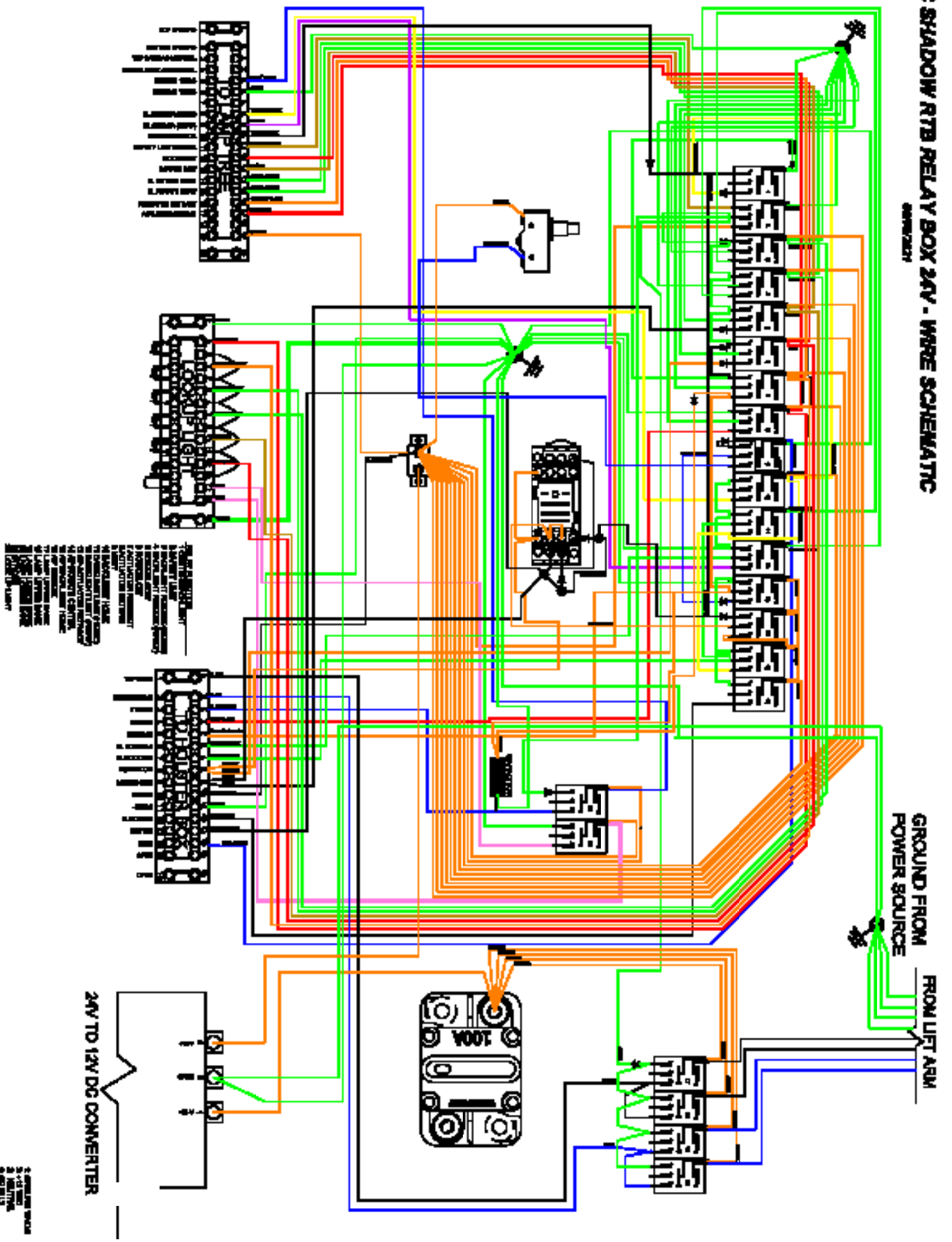

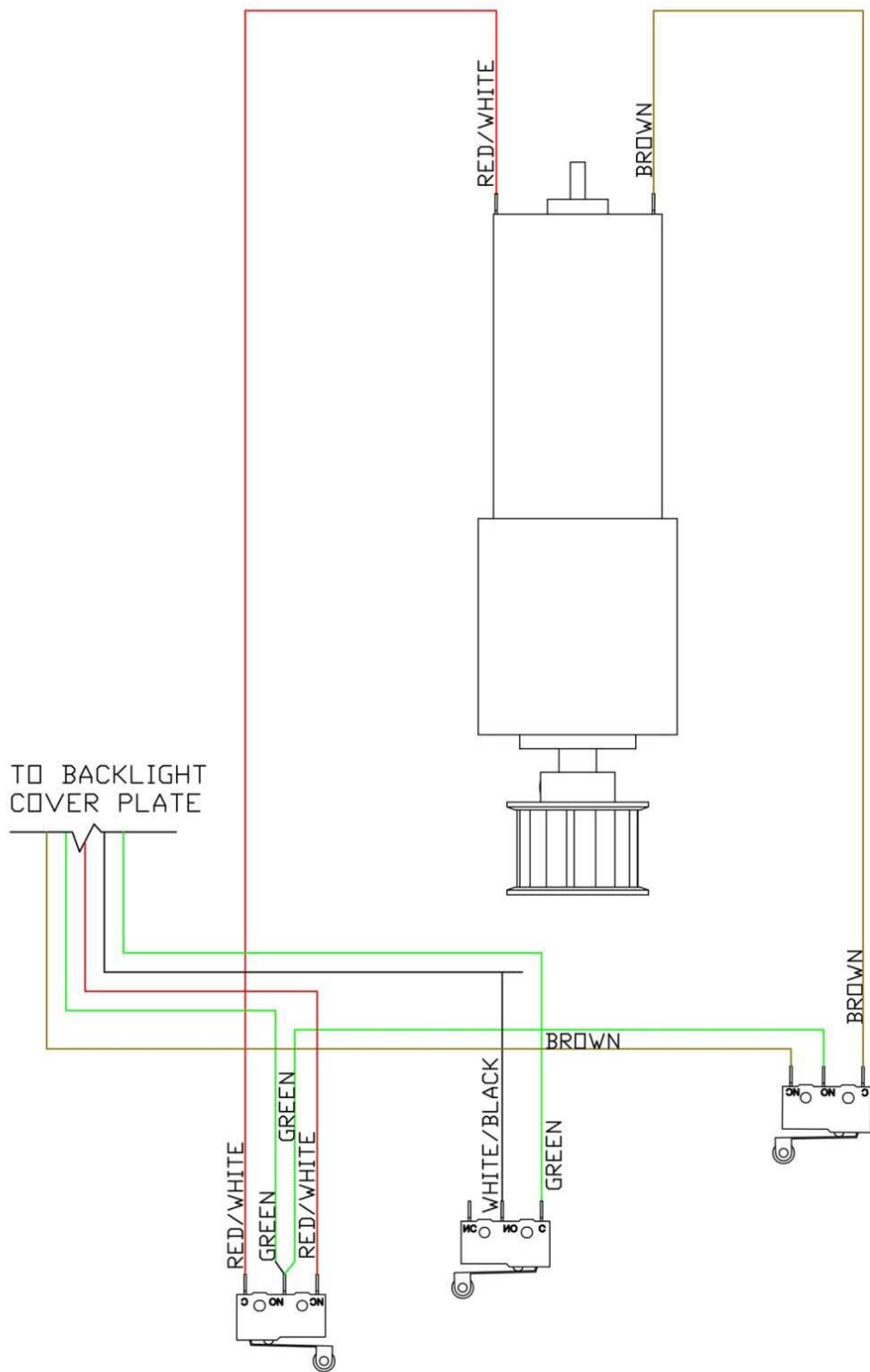

SHADOW RTB
ROTATION ASSEMBLY